

STD 2921-7740 BERICAP

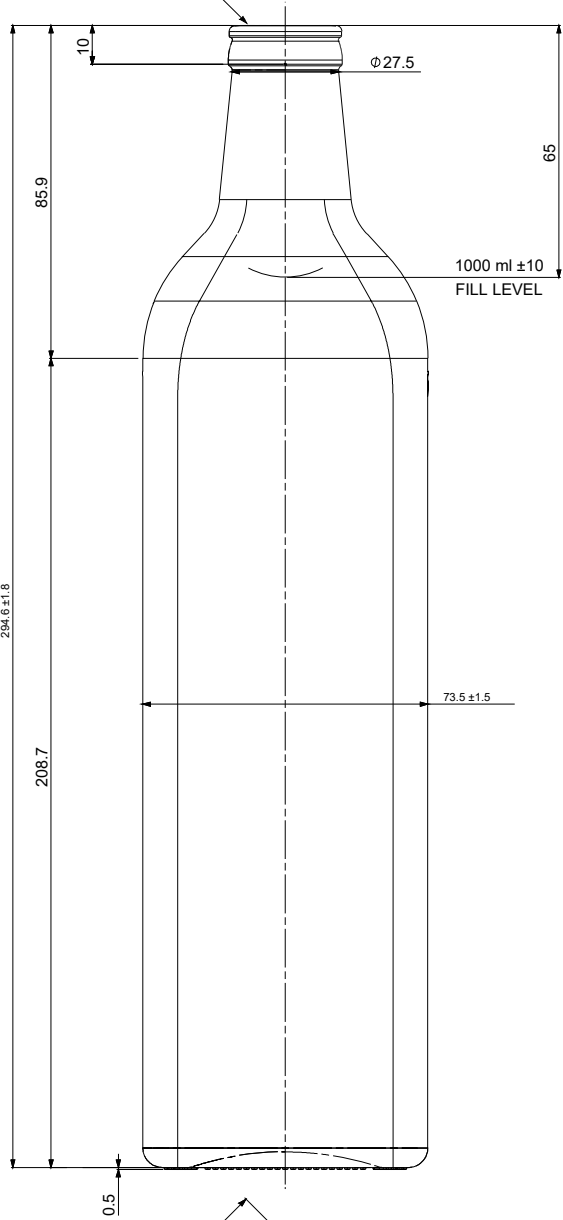

KALIP İŞLERİ ŞEFLİĞİ
TARAFINDAN YAPILMIŞTIR.
(01/06/2020)

b BAŞTÜRK CAM
SANAYİ VE TİCARET A.Ş.

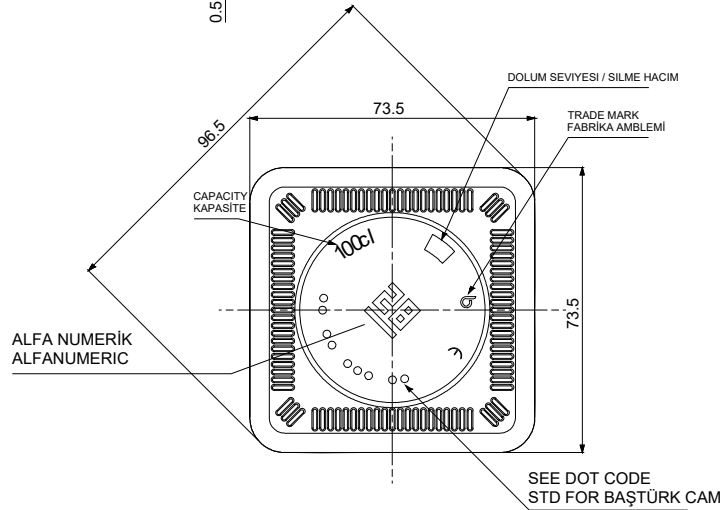

R1	-	-	-	-
REV	ACIKLAMA REMARK	TARİH DATE	CİZEN MADE BY	KONTROL CHECKED BY
DEĞİŞİKLİKLER / REVISIONS				
CİZEN DRAWN BY	-	KAFA STD FINISH	STD 2921-7740 BERICAP	
KONTROL CHECKED BY	-	DOLUM HACMI FILLING CAP (cc)	1000	SILME HACMI BRIMFULL CAP (cc)
ONAYLAYAN CONFIRMED BY	-	AĞIRLIK WEIGHT (gr)	~	C K (TEORİK) W T (THEORET) (mm)
TARİH DATE	01-06-2020	RENK COLOR	FLINT	DENGE ACISI E. ANGLE (°)
ÖLÇEK SCALE	-	1000 CC KOSELI YAG SİSESİ		
Bu tasarımı BASTURK CAM SANAYİ tarafından gerçekleştirilmiş olup bütün hakları müşteriye devredilinceye kadar şirketimize aittir. This design has been realized by BASTURK GLASS INDUSTRY and all rights belong to our company until the customer is transferred.		REFERANS REFERENCE	URUN NO PRODUCT NO	GECİCİ KOD TEMP CODE
		-	N1L001B1R0	-