

KALIP İŞLERİ ŞEFLİĞİ
TARAFINDAN YAPILMIŞTIR.
(13/05/2022)

BAŞTÜRK CAM
SANAYİ VE TİCARET A.Ş.

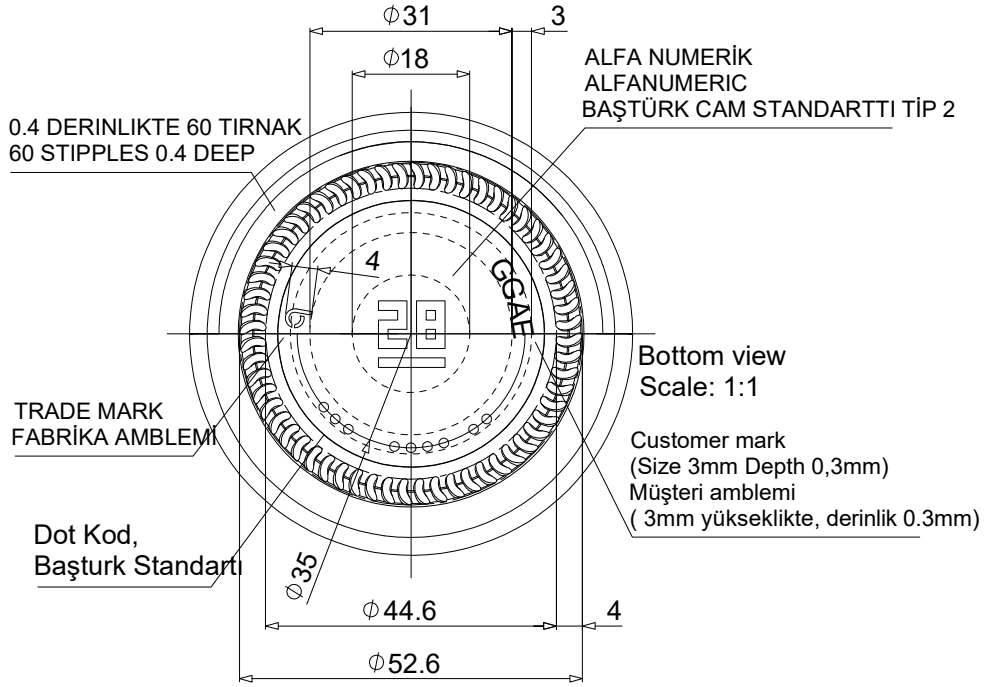

R1	-	-	-	-
REV	ACIKLAMA REMARK	TARİH DATE	CIZEN MADE BY	KONTROL CHECKED BY
DEĞİŞİKLİKLER / REVISIONS				
CIZEN DRAWN BY	-	KAFA STD FINISH	CETIE GME 20.06	
KONTROL CHECKED BY	-	DOLUM HACMI FILLING CAP (cc)	-	SİLME HACMI BRIMFULL CAP (cc) 206 ± 4
ONAYLAYAN CONFIRMED BY	-	AGIRLIK WEIGHT (gr)	~	C K (TEORİK) W T (THEORET) (mm) ~
TARİH DATE	13.05.2022	RENK COLOR	FLINT	DENGE AÇISI E. ANGLE (°) ~
ÖLÇEK SCALE	-	206 CC STANDART KAVANOZ		BASTURK CAM SANAYİ VE TİCARET A.Ş.
Bu tasarım BASTURK CAM SANAYİ tarafından gerçekleştirilmiş olup bütün hakları müşteriye devredilinceye kadar şirketimize aittir. This design has been realized by BASTURK GLASS INDUSTRY and all rights belong to our company until the customer is transferred.		REFERANS REFERENCE	URUN NO PRODUCT NO	GECİCİ KOD TEMP CODE
		-	K20601T1R0	-