

KALIP İŞLERİ ŞEFLİĞİ
TARAFINDAN YAPILMIŞTIR.
(8/03/2024)

b BAŞTÜRK CAM
SANAYİ VE TİCARET A.Ş.

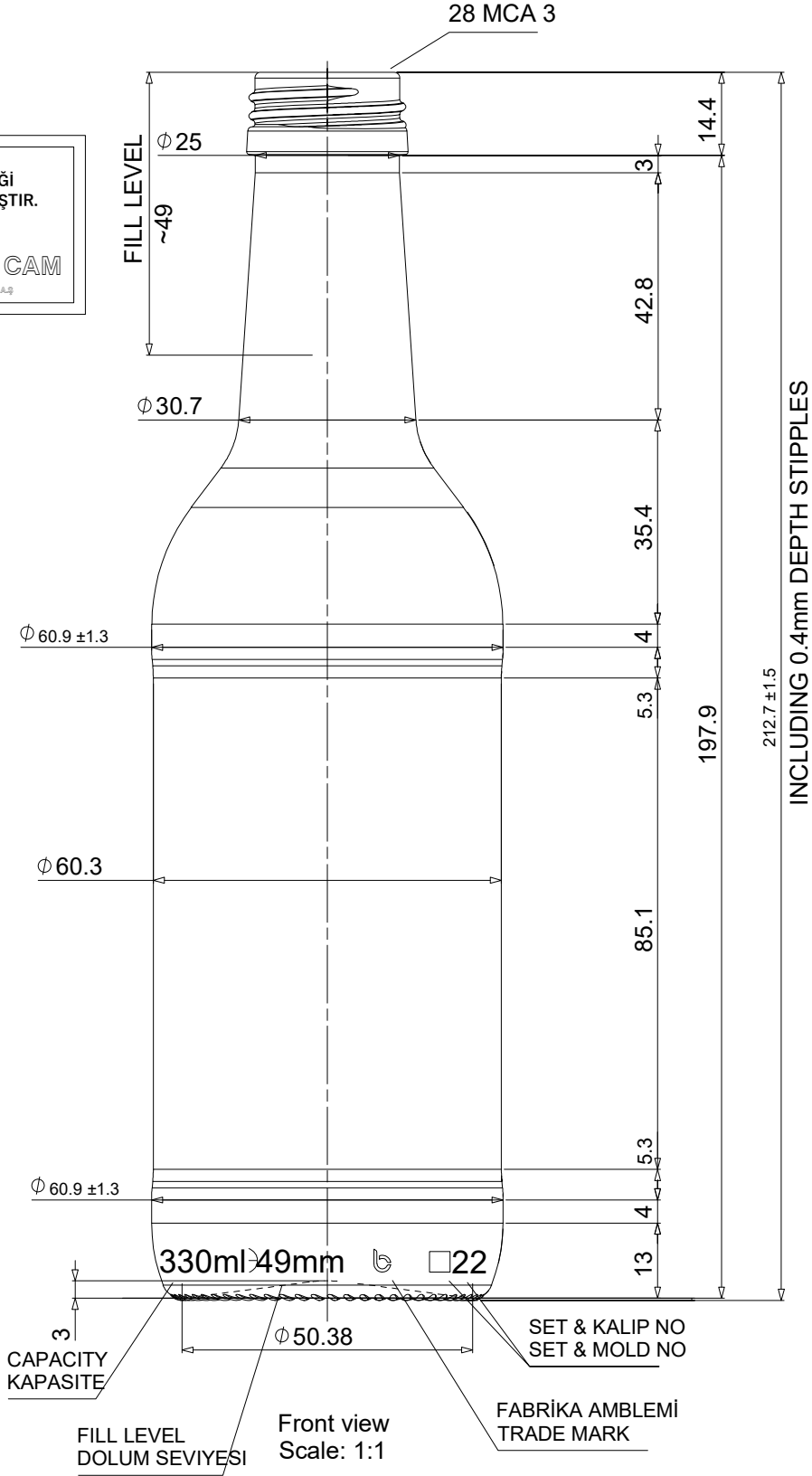

R1	REVIZYON	REVTARİH	REVCİZEN	REVKONTROL
REV	-	-	-	-

DEĞİŞİKLİKLER / REVISIONS

CİZEN DRAWN BY	-	KAFA STD FINISH	ØPMZ635	
KONTROL CHECKED BY	-	DOLUM HACMI FILLING CAP (cc)	330	SİLME HACMI BRIMFULL CAP (cc)
ONAYLAYAN CONFIRMED BY	-	AGIRLIK WEIGHT (gr)	~	C K (TEORİK) WT (THEORET) (mm)
TARİH DATE	8.03.2024	RENK COLOR	FLINT	DENGE ACISI E. ANGLE (°)
ÖLÇEK SCALE	1:1	330 ML MOUNTAIN BOTTLE		



BASTURK CAM
SANAYİ VE TİCARET A.Ş.

Bu tasarım BASTURK CAM SANAYİ tarafından gerçekleştirilmiş olup bütün hakları müşteriye devredilinceye kadar şirketimize aittir.
This design has been realized by BASTURK GLASS INDUSTRY and all rights belong to our company until the customer is transferred.

REFERANS
REFERENCE

-

URUN NO
PRODUCT NO

F33001P1R2

MAX CO2 ORANI

6 gr CO2/Litre